

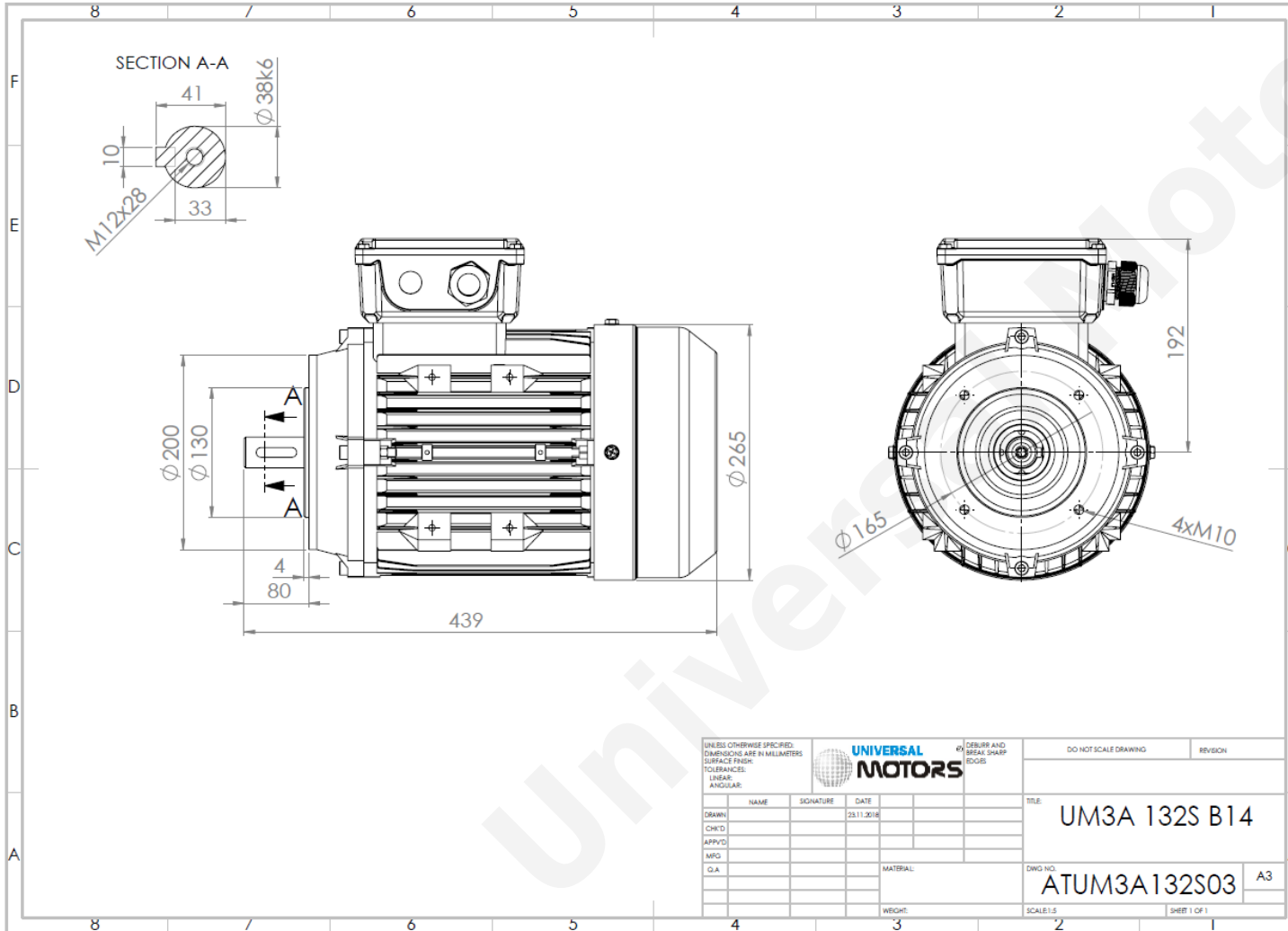

TECHNICAL DATA

Three Phase Electric Motors - Aluminum Frame
 PE31 132S1-2
 5.5 kW / 7.5 Cv
 2920 RPM



Motor type:	PE31 132S1-2
Output:	5.5 kW / 7.5 Cv
Speed (min ⁻¹):	2920 RPM
Frequency:	50 Hz
Voltage:	400 V
Current:	10.1 A
Power factor (Cos Ø):	0.88
Poles:	2
Insulation class:	F
Temperature rise Class:	B
Efficiency 50%:	87.4 %
Efficiency 75%:	88.3 %
Efficiency 100%:	89.2 %
Torque:	18.0 N.m
Tstarting/Tnominal:	2.2
Istarting/Inominal:	8.0
Tmaximum/Tnominal:	2.3
Noise:	85 Db(A)
Weight:	45 Kg
Bearing DE:	6308 2Z C3
Bearing NDE:	6308 2Z C3

Regime - S1

Altitude - 1000m

Environment Temperature - 40°C

CONTACTS:

UNIVERSAL MOTORS Tel: +351 252 299 080
 Rua de São Brás,745 Fax: +351 252 299 089
 4480-782 VILA DO CONDE Mail: geral@universalmotors.pt

* References applied only in the UK